



*An Online PDH Course  
brought to you by  
CEDengineering.com*

## **Current Transformers**

Course No: E03-037

Credit: 3 PDH

---

Velimir Lackovic, Char. Eng.

---



Continuing Education and Development, Inc.

P: (877) 322-5800  
[info@cedengineering.com](mailto:info@cedengineering.com)

[www.cedengineering.com](http://www.cedengineering.com)

## Introduction

The most important roles of instrument transformers are:

- To transform voltages or currents, from a high value to a value that can be easily handled by protection relays and associated instruments
- To separate and insulate the metering circuit from the high voltage
- To provide options for standardization of instruments and protection relays with rated currents and voltages

Instrument transformers are specific transformer types used for measurement of voltages and currents. The common engineering laws are also valid for the instrument transformers. For a short circuited transformer, it can be written:

$$\frac{I_1}{I_2} = \frac{N_2}{N_1} \quad (1)$$

For a transformer at no load, it can be written:

$$\frac{E_1}{E_2} = \frac{N_1}{N_2} \quad (2)$$

The first formula provides the current transformation in proportion to the primary and secondary turns. Second formula provides the voltage transformation in relation to the primary and secondary turns. The current transformer is based on expression (1). Ideally, in the case of a short-circuited transformer the secondary terminal voltage equals to zero and the magnetizing current can be neglected. The voltage transformer is based on expression (2). Ideally, it is a transformer under no-load, where the load current is zero and the voltage drop is caused by the magnetizing current and is therefore negligible.

In reality, the ideal conditions are not met as the instrument transformers have a burden in form of protection relays, instruments and cables. This creates a measuring error in the current transformer due to the magnetizing current, and in the voltage transformer due to the load current voltage drop. Single phase instrument

transformer vector diagram is presented in Figure 1. The turn ratio is 1:1 to ease the representation. The primary terminal voltage “U<sub>1</sub>” is multiplied with the vector subtraction of the voltage drop “I<sub>1</sub>Z<sub>1</sub>” from “U<sub>1</sub>”, which gives the electromagnetic force “E”. “E” is the vector sum of the secondary terminal voltage “U<sub>2</sub>” and the secondary voltage drop “I<sub>2</sub>Z<sub>2</sub>”. The secondary terminal voltage “U<sub>2</sub>” is presented as “I<sub>2</sub>Z”, where “Z” is the burden impedance. The “E” is created by the flux Ø, which lags “E” by 90°. The flux is created by the magnetizing current “I<sub>m</sub>”, which is in phase with Ø. “I<sub>m</sub>” is the no load current “I<sub>0</sub>” reactive component which is in phase with “E”. The resistive part is the power loss component “I<sub>f</sub>”.

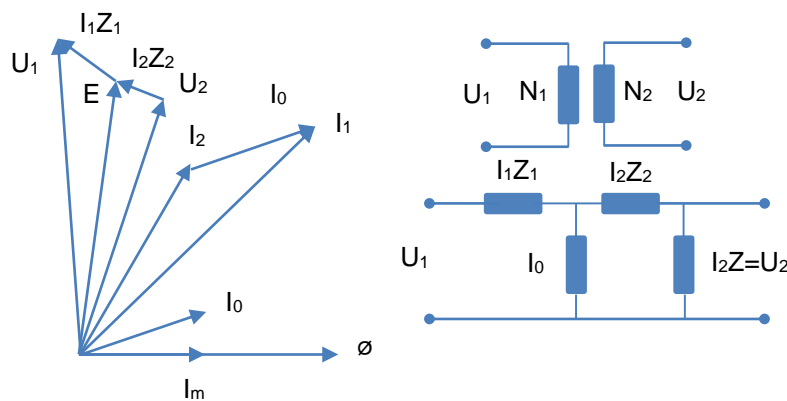

Figure 1. Instrument transformer principle

### Measurement Error

Typically, the current transformer is loaded by impedance. It consists of relays, instruments and the cables. The induced electromagnetic force “E”, needed to achieve the secondary current “I<sub>2</sub>”, through the complete burden “Z<sub>2</sub>+Z”, needs a magnetizing current “I<sub>0</sub>”, which is obtained from the primary side current. The factor “I<sub>0</sub>” is not part of the current transformation and is not used instead of the rated ratio “K<sub>n</sub>”.

$$\text{Nominal ratio } K_n = \frac{I_1}{I_2} \quad (3)$$

Real current ratio “K<sub>d</sub>” can be expressed as:

$$\text{Real ratio } K_d = \frac{I_1 - I_0}{I_2} \quad (4)$$

where “I<sub>1</sub>”, is the rated current of the primary and “I<sub>2</sub>”, is the rated current of the

secondary.

The measuring error “ $\varepsilon$ ” is expressed as:

$$\varepsilon = \frac{K_n I_s - I_p}{I_p} \times 100 \quad (5)$$

where “ $I_s$ ”, is the secondary current and “ $I_p$ ”, is current of the primary. The error in the reproduction will appear, both in amplitude and phase. The amplitude error is known as current, or ratio, error. Definition suggests that the current error is positive, if the current of the secondary is higher than the rated current ratio.

The phase angle error is known as phase error or phase displacement. The phase error is positive, if the secondary current is leading the primary. If the magnetizing current “ $I_0$ ” is in phase with the secondary current “ $I_2$ ” (the maximum error), according to equation 6, error  $\varepsilon$  can be expressed as:

$$\varepsilon = \frac{K_d - K_n}{K_d} \times 100 = \frac{I_1 - I_0}{I_2} \frac{I_1}{I_2} \times 100 = \frac{I_0}{I_1} \times 100 \quad (6)$$

“ $I_0$ ” consists of two elements, a power-loss element “ $I_f$ ”, that is in phase with the secondary voltage and a magnetizing element “ $I_m$ ” that lags  $90^\circ$  and is in phase with the electromagnetic force “ $E$ ”.

The magnetizing current that causes the measuring error, is dependent on several factors (as presented in Figure 2).

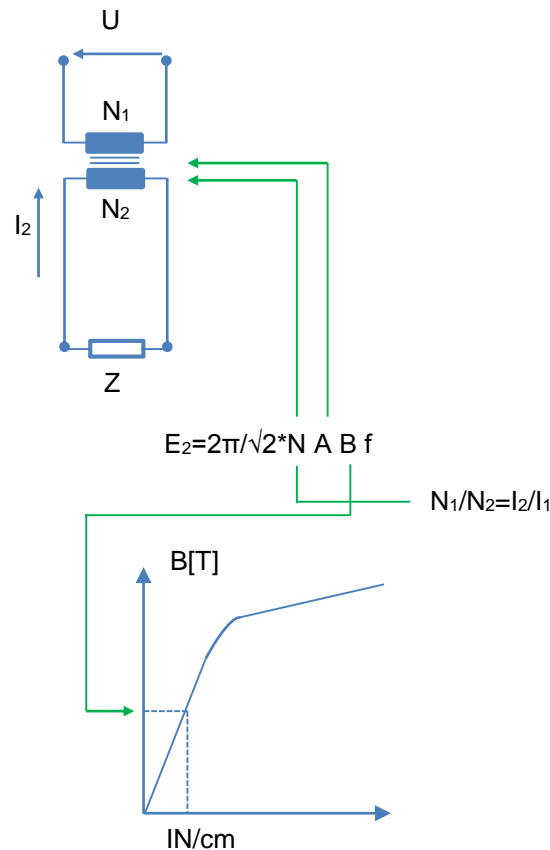

Figure 2. The factors affecting the output of the current transformers and magnetizing current

For the induced electromagnetic force “E”, the formula shown in Figure 2 can be used. The induced electromagnetic force is capable to carry burdens the same size as a transformer.

The burden is described in IEC 185 as the power in VA that can be connected to a current transformer at rated current of the secondary and at a given power factor ( $\cos \varnothing = 0,8$  according to IEC 185). The rated current of the secondary is standardized to 1 and 5 A. The current transformer output voltage presents the transformer capability to carry burden. As presented in Figure 2, three factors will affect the electromagnetic force “E”. It’s the number of secondary turns “N”, the core area “A” and the induction in “B” [Wb/m<sup>2</sup>]. The induction depends of the core material, which influences the size of the magnetizing current. Therefore, secondary turns and the core section are selected for specific application to give the required electromagnetic force output.

## Output of the Current Transformer

The needed output of a current transformer depends on the application and the type of the connected load.

Metering or instruments - Active power, reactive power and current meters work under normal loading conditions. High accuracy for currents up to the rated current (5-120%) is needed for metering cores. Accuracy classes for metering cores are 0.1 (laboratory), 0.2, 0.5 and 1.

Protection and disturbance recording - The information about a primary disturbance must be transferred to the secondary side in the case of protection relays and disturbance recorders. For these cores a lower precision is needed but also a high capability to transform high fault currents and to allow protection relays to measure and clear the fault. Protection classes are 5P and 10P according to IEC 185. Additional cores for transient behavior are described in IEC 44-6.

A number of cores can be placed in each current transformer. Typically, from three to six cores are available. In that case one or two are used for measuring purposes, and two to four for protection purposes.

## Metering Cores

Metering cores must be saturated 10-40 times the rated current depending of the type of burden, to protect instruments and meters from high fault currents. Typically, the energy meters have the lowest withstand capacity. Common values are 12-20 times the rated current. The instrument security factor “ $F_s$ ”, shows the overcurrent as a multiple of rated current at which the metering core will saturate. It is expressed as a maximum value and is applicable only at rated burden. At lower burdens the saturation value roughly increases to “ $n$ ”.

$$n = \frac{R_{CT} + \left(\frac{S}{I_n}\right)^2}{R_{CT} + \left(\frac{S_n}{I_n}\right)^2} \times F_s \quad (7)$$

where “ $S_n$ ” is the rated burden in VA, “ $S$ ” is the real burden in VA, “ $I_n$ ” is the rated current of the secondary in A and “ $R_{ct}$ ” is the internal resistance in  $\Omega$ , at 75 °C.

According to standard IEC 185 the accuracy class is correct from 25 to 100% of the rated burden. To meet the accuracy class and to secure saturation for a lower current than instrument/meter thermal capability the core rated burden has to be well matched to the connected burden.

## Standards

Table 1 below presents the IEC 185 requirement for ratio and angle error for various metering core classes.

Class	Measurement error $\epsilon(\%)$ at $I_n$	Angle error (min) at $I_n$	Purpose
0.2	0.2	10	Metering
0.5	0.5	30	Metering
1	1	60	Instrument
5P	1.0 at $I_n$ , 5 at ALF* $I_n$	60	Protection
10P	3 at $I_n$ , 10 at ALF* $I_n$	180	Protection

Table 1. Current transformer accuracy classes - For metering classes there are additional requirements for 5 and 20% of  $I_n$

## Protection Cores

The main features of protection CT cores are:

- Lower accuracy than for measuring transformers
- High saturation voltage
- Small or no turn correction

The factors that describe the cores are:

- The composite error with class 5P and 10 P. The error is then 5% and 10% respectively, at the specified accuracy limit factor (ALF) and at rated burden.
- The Accuracy Limit Factor “ALF” shows the overcurrent as a multiple, times the rated current, up to which the rated accuracy (5P or 10P) is fulfilled (with the

connected rated burden).

- The accuracy limit factor (ALF) is expressed as a minimum value
- The overcurrent factor is changed when the burden is different to the rated burden. The equation for the achieved overcurrent factor “n” for a connected burden, that is different than the rated burden, is similar to the formula for metering cores.

$$n = \frac{R_{CT} + \left(\frac{S}{I_n}\right)^2}{R_{CT} + \left(\frac{S_n}{I_n}\right)^2} \times ALF \quad (8)$$

where “S<sub>n</sub>” is the rated burden in VA, “S” is the actual burden in VA, “I<sub>n</sub>” is the rated secondary current in A and “R<sub>ct</sub>” is the internal resistance in Ω, at 75 °C. Typically, the burdens are purely resistive and much lower than the previously used burdens.

### Instrument Transformer Transient Processes

The short-circuit current can be defined as:

$$i_k = I_k \left[ \cos \phi \times e^{\frac{-t}{T_1}} - \cos(\omega t + \phi) \right] \quad (9)$$

where “i<sub>k</sub>” is the instantaneous value of the fault current, “I<sub>k</sub>” is the instantaneous amplitude value of the fault current and “ϕ” is the phase angle, at the fault inception. The variable “ϕ<sub>1</sub>” is set to zero, for a pure resistive burden which is the normal situation. That simplifies the calculation. The first part of the equation is the DC component of the fault current and the second part is the pure AC element.

The “e<sup>-t/T<sub>1</sub></sup>”, suggests that the DC component is a decaying exponential function, with the time constant “T<sub>1</sub>”. The maximum amplitude is dependent on where on the voltage sine wave the fault happened. Regarding the protection relays that are supposed to function during the fault, it’s important to verify the core output under transient conditions.

The fault must happen between two extreme conditions:

1. ϕ=90°, for example a fault at voltage maximum. The fault current will be a pure



sinus wave. To transform the fault current without saturation, the ALF factor has to be  $ALF \geq I_k/I_n$ .

2.  $\varnothing=0^\circ$ , for example a fault at voltage zero. The short circuit current will have complete symmetry with a maximum DC part. These situations are rare as faults typically happen close to voltage maximum rather than close to voltage zero.

The DC part will build up a DC flux in the core and an interposed AC flux. The flux will increase and decrease according to the time constants. The rise depends on the network time constant " $T_1$ " (L/R) and the decay is in line with the current transformers secondary time constant " $T_2$ ". This is shown in Figure 3 and Figure 4.

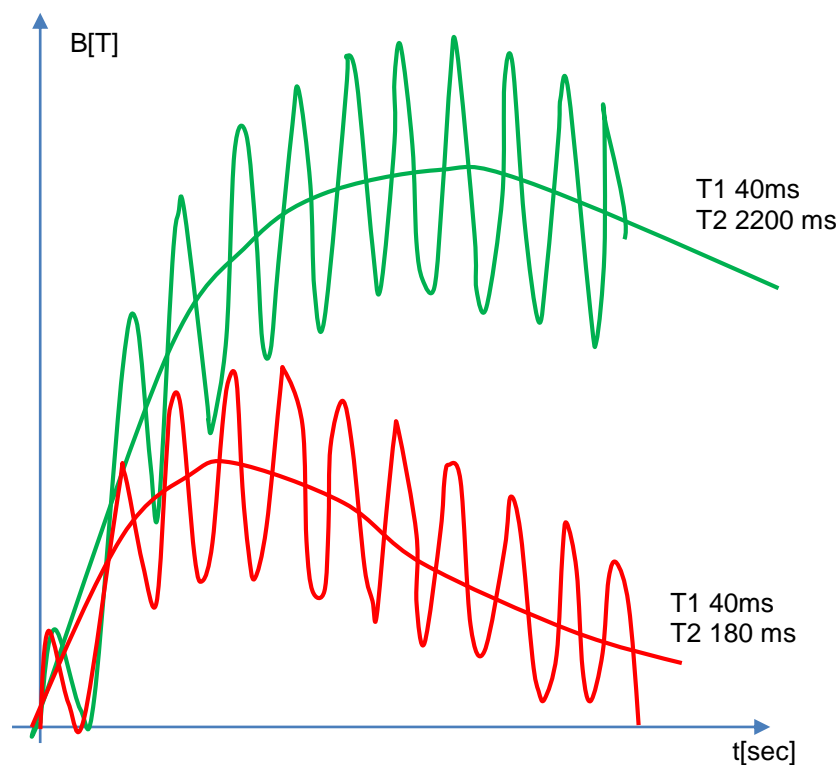

Figure 3. AC and DC flux are time dependent, at faults with full DC component and with different primary and secondary time constants

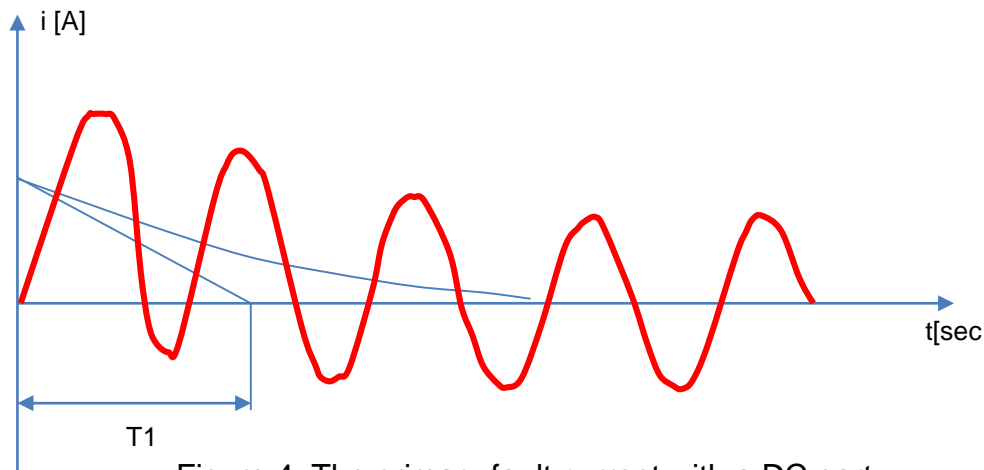

Figure 4. The primary fault current with a DC part

“ $T_2$ ” is the current transformer secondary time constant “ $L_0/R_0$ ”, where “ $L_0$ ” is the inductance of the secondary winding and “ $R_0$ ” is the resistance of the secondary winding.

The quotient between the maximum value of the DC component and the maximum value of the AC component is known as the transient factor “ $K_T$ ” and is expressed as:

$$K_T = \frac{\phi(ac\ flux) \times (\omega T_1 \cos \phi^2 - \sin \phi^2)}{\phi(ac\ flux)} \quad (10)$$

which for a resistive burden ( $\cos \phi^2 = 1.0$ ) gives “ $K_T = \omega T_1$ ”, which with a primary time constant “ $T_1 = L/R = 100\text{ms} = 31.4$ ”, which in turn gives a DC flux “31.4” multiplied with the AC flux.

To correctly transform the short circuit current, the protection core needs to have an ALF factor “31.4” multiplied with the ALF factor for case 1.

The situation becomes even worse if a quick auto-reclosing is applied. At fault current breaking the core will be left magnetized to “ $\phi_{max}$ ” as the breaking is accomplished at current zero crossing, for example voltage is close to maximum and the flux is also close to maximum.

The remanence flux “ $\phi_r$ ” in the core will decay according to expression (11) and as shown in Figure 5.

$$\phi_r t = \phi_{max} \times e^{-\frac{t}{T_2}} \quad (11)$$

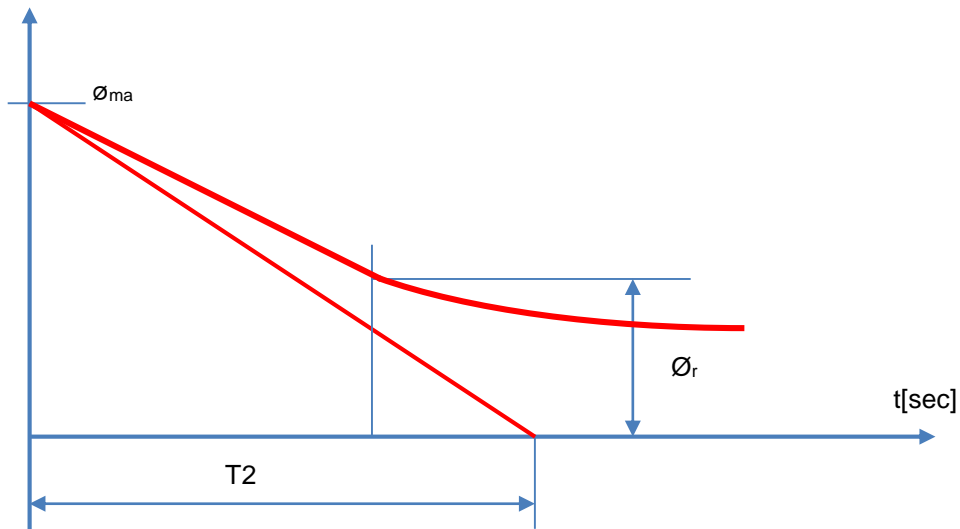

Figure 5. The flux decay and the remanence flux

At a reclosing for a permanent fault after the time “t” (the same flux direction is foreseen in the worst case), a part of the core is already used for the remanence flux. To manage a correct transformation of the current during an auto reclosing sequence the core needs to be additionally increased with a remanence factor “K<sub>r</sub>”. This factor is according to IEC:

$$K_r = \frac{f_{max}}{f_{max} - f_r} \quad (12)$$

Therefore, the current transformer cores have to be increased with the transient and the remanence factor “K<sub>T</sub>” and “K<sub>r</sub>”, respectively. This is needed if saturation isn’t allowed during the transient fault having a full DC offset and with an auto reclose sequence.

Ideal transformation of short circuits using DC component and during auto reclose will set high over dimensioning demands. All clearances of parameters will be multiplied and can set unrealistic requirements on core size after multiplying with “K<sub>T</sub>” and “K<sub>r</sub>”.

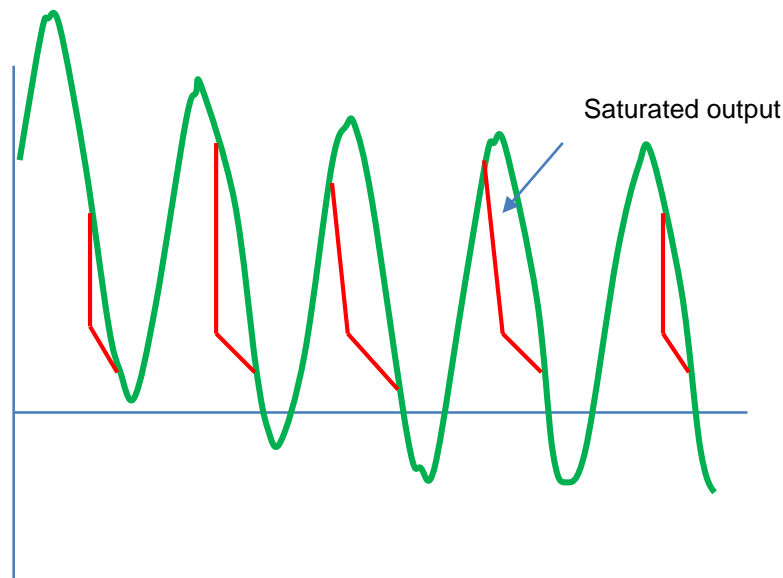

Figure 6. Secondary current at DC saturation, for some cycles the positive part of the sine wave will be destroyed

### CT Core Selection

Some typical guidelines for choosing current transformer cores, for metering and protection purposes are described.

Select the rated current - The primary rated current is chosen to be 10-40% bigger than the object rated current. This always provides a high resolution of the metering equipment and instruments. For the protection cores it can be of interest to have the biggest possible ratio as this gives the least requirements of core data. The modern protection relays have wide measuring ranges. A primary or secondary tap to obtain several ratios can be useful in metering cores. However, keep in mind that the output is decreased when fewer turns are used.

The secondary current can be 1 or 5 A. Nowadays, 1A is the dominating as the protection and metering equipment have so low burdens. The cable burden is " $I^2R$ " which suggests that a 1A circuit has 25 times lower cable burden, measured in VA, than a 5A circuit. This implies that cores can be made smaller which reduces costs.

Select burden - Do not use an over dimensioned burden more than absolutely necessary. A too high rated burden in comparison to actual burden can mean that

the metering equipment is destroyed as the security factor “F<sub>s</sub>” is valid at rated burden. For protection relay cores an extra burden clearance can give unrealistic core sizes after multiplication with factors “K<sub>T</sub>” and “K<sub>r</sub>”.

Select “F<sub>s</sub>” and ALF factors - Select the correct security factor “F<sub>s</sub>” and Accuracy Limit Factors “ALF” that depend on the type of connected equipment. Always refer to the product description and verify the overcurrent capability for instruments and meters and the requirement on core output for protection relays. Keep in mind possible burden clearances which will affect the real overcurrent factor.

In reality, all current transformer cores need to be specially adapted for their application in each station.

Chose accuracy - Do not specify bigger demands than necessary. For metering cores particularly with A-turns less than about 400-500 a too high requirement can involve extra expenses since a more expensive core material has to be used.

### **Rules of Thumb**

The resistance of the secondary, R<sub>CT</sub>, is crucial for the CT output and has to be limited, particularly for 1 A high ratio CT's, to give an efficient use of the current transformers. For example, the core voltage output needs to be used to support the connected burden and not the internal resistance. Objective could be to always have lower internal resistance than rated burden, if possible much lower. The following rule of thumb can be used:

$$R_{CT} \leq 0,2 - 0,5 \Omega \text{ per } 100 \text{ turns}$$

Cores are considered as big when the voltage output is of range 1 - 2 V per 100 turns and medium size cores have outputs 0,5 - 1 V per 100 turns. Typically, the resistance values are smaller for 5 A circuits as the winding has greater area for 5 A than for 1 A. Nevertheless, the problem that the resistance of the secondary is high is happening mainly on 1 A as the number of turns are five times bigger for 1 A than for 5 A. Therefore, it is important to keep core size and secondary resistance down to obtain useful cores where the voltage output is mainly generating current to the

load and not giving internal voltage drop and power loss.

### CT Requirements

Many protection relay types are used in a power system. Distance protection relays, differential protection relays, overcurrent protection relays of different types etc. will all have different demands on the current transformer cores depending on the design of the specific protection relay. Instantaneous and delayed protection relays will also have various demands. Frequently, a DC component of the fault current has to be considered for the instantaneous types of protection relays. Modern solid-state protection relays, of static or numerical types, give a much lower burden on the current transformer cores and typically also have lower requirements on the core output as they are typically made to work with saturated CT cores which was not the case for the old types of electro-mechanical protection relays.

Brief description of requirements that modern solid state protection relays will set on current transformer cores is provided below. For specific types user has to refer to respective relay manuals and to tests of behavior at saturated current transformers completed with the different products.

To describe the general expressions used, a normal current transformer circuit is shown in Figure 7.

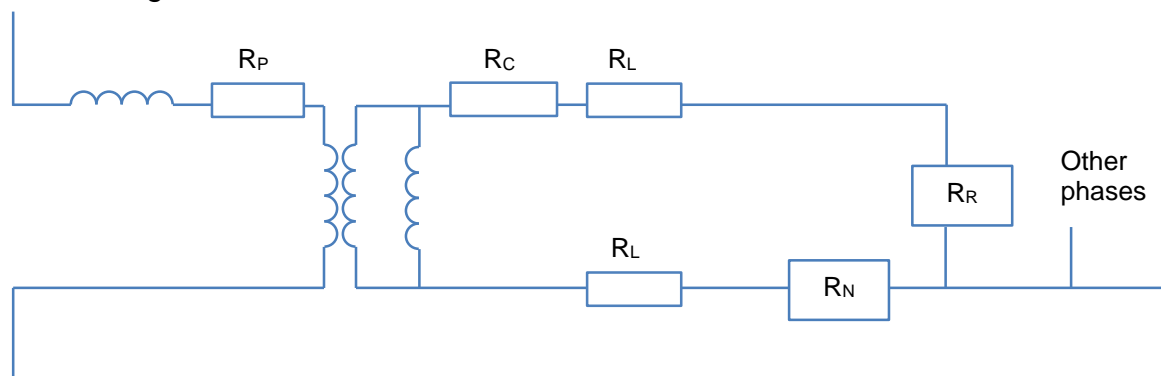

Figure 7. The current transformer scheme with magnetizing reactance and secondary resistance

For phase to phase short circuits the loop-resistance will include the cable resistance “ $R_L$ ” plus the phase measuring relay resistance “ $R_R+R_{CT}$ ”. For phase to ground fault loops the resistance will include two times the cable resistance “ $R_L+R_i$ ” plus the

overall resistance of phase and neutral measuring relays “ $R_R+R_N+R_{CT}$ ”. Core voltage output can either be the knee-point voltage or the secondary voltage output “ $E_2$ ”. It is computed using 5P or 10P data, ALF and the resistance of the secondary according to:

$$E_2 = ALF \times I_n(R_{CT} + R_n) \quad (13)$$

where

“ $E_2$ ” is the secondary limiting electromagnetic force

“ $I_n$ ” is the CT rated secondary current

“ $R_{CT}$ ” is the CT secondary resistance at 75°C and

“ $R_n$ ” is the CT rated burden, computed as resistance.

Typically, modern relays give a pure resistive burden. Certainly, values provided in ANSI or other standards, can be used in similar ways to determine the cores secondary output and the achieved value can be used instead. The voltage output difference, at selected core definition, is around 10-20% and is not of importance for the calculation.

### Overcurrent Protection Relays

Overcurrent protection relays are used both for short-circuit and ground-fault protection. They can be instantaneous or delayed, definite or inverse time. Current transformer cores have to provide adequate output to ensure correct operation.

The needed CT core output is presented below:

Instantaneous protection - Core should not saturate for an AC current, smaller than “ $2xI_{set}$ ”. The DC component doesn’t have to be considered as overcurrent protection relays are made with short impulse limit time to secure operation also when only a very short current pulse is achieved due to heavy saturated current transformer cores. Due to high setting of instantaneous elements the requirement will typically be

quite high.

### **Inverse Time Delayed Overcurrent Protection Relays**

Core may not saturate for an AC current less than “ $20I_{set}$ ”. The 20 times factor is needed to make sure that the inverse time characteristic will be correct and no extra delay will be introduced in some protection relay (due to saturation in a CT core). Such a delay would mean a lack of selectivity. If needed, the factor 20 can be altered to “the maximum fault current of interest for selectivity divided by the set current”.

### **Definite-Time Delayed Overcurrent Protection Relays**

Core may not saturate for a current “ $I$ ” less than “ $2I_{set}$ ” to ensure operation. The current output is determined as:

$$I = \frac{E_2}{R_{loop}} \quad (14)$$

Both phase and ground-faults values need to be checked when ground fault currents are high. Nevertheless, the short circuit protection will impose the highest requirements. Overcurrent protection relays have moderate requirement on accuracy. 5P or 10P class can be used without any issues. If a low accuracy class is used this has to be considered when choosing the setting. Typically, the margin has to be increased for ground faults when the summation of the three phases is done as the measuring error is increased when few current transformer cores are involved.

### **Impedance and Distance Protection Relays**

Distance protection is an instantaneous impedance measuring protection for medium voltage and high voltage transmission lines. The typical demand on current transformer cores which can be used for modern static and numerical distance protection relays is that the core may not saturate within 50ms for a fault at the end of zone 1. Saturation time differences between different relay types exist but 50ms is generally suitable. For detailed data about the demands, user needs to refer to the manual of each protection relay. Saturation is allowed for internal faults since the protection relays are made to function with saturated CT core without any delay in



operation. Saturation due to the DC component has to be considered due to the instantaneous protection operation.

The empiric formula for a CT free from saturation is:

$$E_2 = I_{s1} \left( \frac{X}{R} + I \right) (R_{CT} + R_L) \quad (15)$$

where

“ $I_{s1}$ ” is the current through the own line for a short circuit at set reach of zone 1. “ $I_{s1}$ ” is determined as:

$$I_{s1} = \frac{U}{\sqrt{3} \times Z_s} \quad (16)$$

where

$Z_s$  is the complete impedance for a fault at zone 1 reach. X/R is the ratio of X/R up to the zone 1 reach.

$R_{CT}+R_L$  provide the current transformer core secondary resistance and the connected burden to the current transformer terminal. To determine the needed output voltage for a saturated free voltage the following expression can be used. The secondary time constant is considered as high:

$$E_2 = I_{s1} \left( T_1 \times w \left( 1 - e^{-\frac{0.05}{T_1}} \right) + 1 \right) (R_{ct} + R_1) \quad (17)$$

where

$T_1$  is the primary time constant.

### Differential Protection Relays

There are many types of differential protection relays that can be used for many different applications. The most commonly used differential relays are described below:

## High Impedance Protection Relays

CT cores used together with high impedance protection need to all have identical turn ratio. Turn correction is not allowed. Typically, separate cores have to be provided for this kind of protection on all involved current transformers. Nevertheless, high impedance relays used for restricted earth fault protection can be used on the same core together with the transformer differential protection if interposing CTs or insulated input transformers are provided.

All cores need to have a saturation voltage  $U_{sat} > 2U_r$  to allow operation for internal faults. Relay operating voltage  $U_r$  is determined as:

$$U_r > I_{smax}(R_{ct} + R_{loop}) \quad (18)$$

where

$I_{smax}$  is the maximum secondary through fault current

$R_{Loop}$  is the max loop resistance seen from connection point

## Transformer Differential Protection

Transformer differential protection relays are percentage restraint differential protection relays. The operation level is increased at through faults to provide stability even with the tap changer in an end position and with differences between high and low voltage CT cores. Typically, the CT cores must not saturate for any through fault but the percentage stabilization and an internal stabilization for current transformer saturation means that the requirement can be limited. Following expression needs to be used:

$$E_2 = K_{TF} \times I_{smax} (R_{ct} + R_{Loop}) \quad (19)$$

where

$K_{TF}$  is the transient overdimensioning factor

$I_{smax}$  is the maximum secondary through fault current

$R_{Loop}$  is the maximum loop resistance seen from connection point.

$K_{TF}$  has to be selected based on the provided protection relay type and final application.

For one and a half, ring busbar or two breaker bus arrangements separate stabilizing inputs need to be used for CT's where through fault currents can happen.

The modern protection relays are made to work correctly for heavy internal faults and with saturated CT's to ensure that stability is achieved for outer faults. It is suggested to use as similar saturation level for installed current transformers. Accuracy class 5P according to IEC185, or similar accuracy class in other standards, should be used.

### **Pilot Wire Differential Relay**

Pilot wire differential protection relay works with a circulating current in the pilot wires. Current transformer cores have to be provided with the same ratio at the two terminals but don't need to be of the same type. The CT accuracy demands are based on the most serious external fault under symmetrical current conditions. Under these conditions and with the CT burden composed of the CT secondary and lead resistances, plus an allowance of 5 VA for the biggest single phase burden of the pilot wire differential summation CT, the CT shouldn't exceed 10% accuracy. This can be written as:

$$I_s = \frac{E_2 - E_z}{R_l + R_{ct} + R_{sct}} \quad (20)$$

where " $I_s$ " is the maximum secondary fault current, " $E_2$ " is the CT's secondary voltage with 10P (or 5P) accuracy and " $E_z$ " is the voltage across the regulating diodes reflected to the primary side of summation CT.

" $R_l$ " is the cable resistance (one way for line-line and two way for line-ground faults), " $R_{ct}$ " is the CT's secondary winding resistance and " $R_{sc}$ " is the summation CT resistance, reflected to the primary side of the summation current transformer.

If selected in that way, saturation due to DC component in asymmetrical fault currents will not cause mal-operation. Also CTs that saturate during an internal fault, due to AC or DC, will not prevent operation. General prudence recommends a limitation of the maximum fault currents to 100 times nominal current or 250 A secondary whichever is the smallest.

When current transformers of similar characteristic are given at both ends of the line the through faults will saturate the current transformers at both ends. In that case smaller cores can then be used.

The expression:

$$E_2 \geq 20 \times I_n \left( R_{CT} + R_I + R_2 + \frac{5}{I_{n2}} \right) \quad (21)$$

has to be fulfilled, where:

$R_2$  is the load of other equipment connected to the same core

$R_I$  is cable resistance (one way for line-line and two-way for line-ground faults. If ground fault current is low only one way is sufficient).

### Busbar Differential Protection

Pilot wire differential protection and busbar differential protection are moderate impedance restraint protection relays. Their restraining characteristic depends on CT saturation for both internal and external faults. To ensure operation at internal faults the CT secondary limiting electromagnetic force “ $E_2$ ” or the CT knee-point voltage is expressed as:

$$E_2 \geq 2U_{rs} = I_{d1}(R_{dt} + 28) + n_d V_{d3} \quad (22)$$

where

$I_{d1}$  is the operating current

$R_{dt}$  is the complete differential circuit resistance

$28 \Omega$  - is the secondary winding resistance of the auxiliary CT in the differential circuit, referred to the primary side

$n_d V_{d3}=20V$  - is the forward voltage drop at the full wave rectifier in the auxiliary CT at the differential circuit secondary side

### Loop Resistance

The allowable loop resistance for secure through fault stability seen from the protection relay can be expressed as:

$$R_{IX} = \frac{R_{dt} \times S}{(1-S)} \quad (23)$$

where

S is the setting of the slope

$R_{dt}$  is the complete differential circuit resistance and is calculated as follows:

$$R_{dt} = n_d^2 \times R_{d3} + R_{md} + (R_a \times R_{d11}) \quad (24)$$

where

$n_d$  is the turns ratio of the auxiliary CT in the differential circuit and equals 10

$R_{d3}$  is the resistance of the fixed resistor

$R_{md}$  is the short circuit impedance of the auxiliary CT in the differential circuit

$R_a$  is the resistance of the alarm relay

$R_{d11}$  is the resistance of the variable resistor

The loop resistance detected from the protection relay can be expressed as:

$$R_{I_{max}} = (R_2 + R_I) \times n_{mx} \quad (25)$$

where

$R_2$  is the main transformer secondary resistance

$R_l$  is the cable loop resistance

$I_{mx}$  is the auxiliary transformer ratio

### Fault Locator Type

Requirement on current transformer cores, used for fault locator, is that the core is not allowed to saturate within 30ms from the fault inception for a fault at a location where the maximum measuring accuracy is needed. The formula for saturation free CT in 30ms can be written as:

$$E_2 = K_{tf}(R_{ct} + R_l) \quad (26)$$

The transient dimensioning factor  $K_{tf} = \phi_{max} / \phi_{ssc}$

The flux at 30ms,  $\phi(0,03)$  is:

$$\phi(0.03) = \phi_{ssc} \left( \frac{\omega T_1 T_2}{T_1 - T_2} \left( e^{-\frac{0.03}{T_1}} - e^{-\frac{0.03}{T_2}} \right) + 1 \right) \quad (27)$$

where

$T_1$  is the primary net time constant in seconds

$T_2$  is the secondary time constant in seconds

$\phi_{ssc}$  is steady state flux corresponding to the sinusoidal current

And “ $\omega$ ” is the angle speed, for example  $2\pi f$  where “ $f$ ” is the net frequency.

For conventional CT's with a high  $T_2$  compared to  $T_1$  this can be simplified:

$$E_2 = I_{s1} \left( T_1 \times \omega \left( 1 - e^{-\frac{0.03}{T_1}} \right) + 1 \right) (R_{ct} + R_l) \quad (28)$$

where

$I_{s1}$  is the maximum fault current for which the accuracy is needed

$R_1$  is the loop resistance sensed from core terminals. CT ratio has to be chosen to ensure that phase component of the fault current is bigger than 10% of rated current. Accuracy class 5P according to IEC185 needs to be fulfilled.

### **Fault Locator in Distance Relay**

The built-in fault locator option in the line protection terminals is made with the same measuring algorithm as in fault locator type. However, the time window for measurement is shorter and therefore a time to saturation of 20ms can be used for a fault at location where maximum accuracy is needed. Similar formula as for fault locator relay type, but with 20ms instead of 30ms, should be used. Typically, it's sufficient to use cores suitable for the distance protection without special verification. Nevertheless, when lines are long and requirement on cores from distance protection low, a high precision can be needed for faults much closer to the station. Then the requirement set by the fault locator will often be dimensioning even though the allowed time to saturation is much shorter.

Certain saturation can also be allowed without loss of measuring precision due to the analogue and digital filtering of current signals. There is also a possibility to recalculate the result given by the fault locator in above products using a different measuring loop if a heavy DC saturation is discovered in some of the involved phases. This can give a great improvement as the DC component will differ between phases for multi-phase faults.

### **Breaker Failure Relay Type**

The requirement on a core feeding a breaker failure relay can be expressed as:

$$E_2 \geq 15 \times I_{set}(R_{ct} + R_1) \quad (29)$$

or:

$$E_2 \geq 0.2 \times I_n \times n(R_{ct} + R_1) \quad (30)$$

Whichever is bigger.

Where:

$R_{ct}$  is CT secondary resistance

$R_1$  is the complete loop resistance seen from CT terminals

$I_{set}$  is the set current

$I_n$  is the CT secondary rated current

$n$  is maximum primary fault current/CT primary rated current.

This will allow the operation of the breaker failure protection relays even with CT saturation. Breaker failure relay is made with an energy storing to provide a continuous energizing of the output, even with heavy saturated current transformers, and with short reset pulses.